

# TECHNICAL DATA SHEET



## LPI® STORMMASTER ESE



- Fully Tested Family of Air Terminals in Compliance to NF C 17-102 (2011)
- Family of Air Terminals; Aluminium and Stainless Steel
- Easy to Install
- All Stormmaster Terminals Tested by the ITE HV Laboratory in Europe, which has National (ENAC) and International (ILAC / ISO / IEC) Accreditation

- Cost Effective Lightning Protection
- Free Lightning Protection Designs & Risk Assessments Available on Request
- For connection to HVSC Plus or 2 inch GI pipe



TECHNICAL DATA SHEET

LPI® STORMASTER ESE

Protection Performance

The protection radius (Rp) of a Stormaster ESE terminal is calculated using the formula defined by the French National Standard NF C 17-102 (September 2011), namely:

(1)  $R_p[h] = \sqrt{2rh - h^2 + \Delta[2r + \Delta]}$  for  $h \geq 5\text{ m}$

and

(2)  $R_p = h \times R_{p5} / 5$  for  $2 \leq h < 5\text{ m}$

Where **h** = actual height of Stormaster terminal above the area to be protected (m).

**Rp5** = value of Rp from Eqn. [1] when h = 5 m

**r** = 20 m for protection level I [Very High protection]

30 m for protection level II [High protection]

45 m for protection level III [Medium protection]

60 m for protection level IV [Standard protection]

**Δ** = Stormaster time and height advantage according to the Stormaster model installed:

Stormaster-ESE-15: Δ = 15 μs

Stormaster-ESE-30: Δ = 30 μs

Stormaster-ESE-50: Δ = 50 μs

Stormaster-ESE-60: Δ = 60 μs

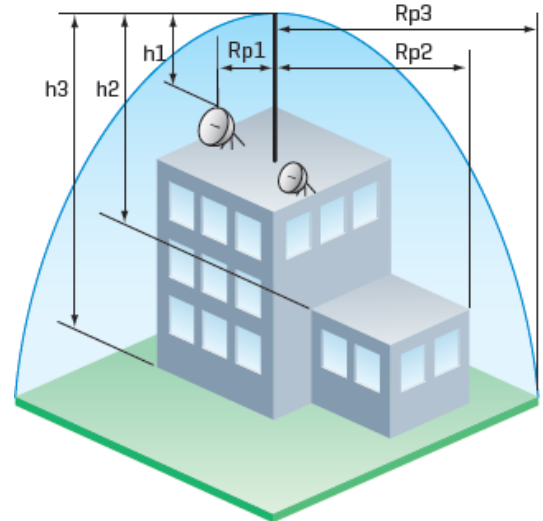

**NOTE:** See following LPI publications for additional information on the Stormaster range and NF C 17-102 (2011) Standard (available on request):

- Technical Paper - ESE HV Test Requirements
- Technical Paper – French Standard NF C 17-102 (2011)
- Stormaster Catalogue
- Stormaster Installation Manual

PROTECTION RADIUS, Rp (m)											
h = height of Stormaster ESE terminal above the area to be protected (m)	2	4	5	6	10	15	20	45	60	80	100
<b>Protection Level I (Very High)</b>											
Stormaster ESE 15	13	25	32	32	34	35	35	35	35	35	35
Stormaster ESE 30	19	38	48	48	49	50	50	50	50	50	50
Stormaster ESE 50	27	55	68	69	69	70	70	70	70	70	70
Stormaster ESE 60	31	63	79	79	79	80	80	80	80	80	80
<b>Protection Level II (High)</b>											
Stormaster ESE 15	15	30	37	38	40	42	44	44	44	44	44
Stormaster ESE 30	22	44	55	55	57	58	59	59	59	59	59
Stormaster ESE 50	30	61	76	76	77	79	79	79	79	79	79
Stormaster ESE 60	35	69	86	87	88	89	89	89	89	89	89
<b>Protection Level III (Medium)</b>											
Stormaster ESE 15	18	36	45	46	49	52	55	60	60	60	60
Stormaster ESE 30	25	51	63	64	66	69	71	75	75	75	75
Stormaster ESE 50	35	69	86	87	88	90	92	95	95	95	95
Stormaster ESE 60	39	78	97	97	99	101	102	105	105	105	105
<b>Protection Level IV (Standard)</b>											
Stormaster ESE 15	20	41	51	52	56	60	63	73	75	75	75
Stormaster ESE 30	29	57	71	72	75	78	81	89	90	90	90
Stormaster ESE 50	38	76	95	96	98	100	102	109	110	110	110
Stormaster ESE 60	43	85	107	107	109	111	113	119	120	120	120

Contact LPI for Protection Radius for Level I+ and Level I++

TECHNICAL DATA SHEET

LPI® Stormaster ESE Terminals

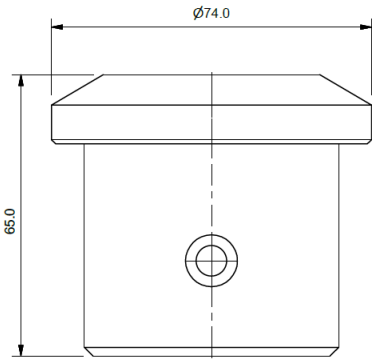
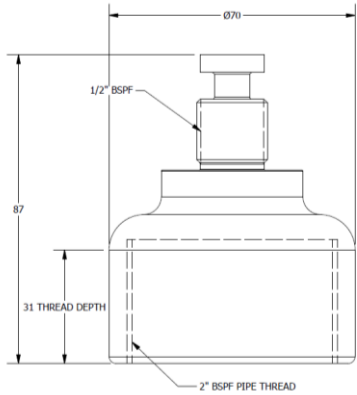
Standard Adaptor	GI Adaptor
<ul style="list-style-type: none"> <li>For use with FRP mast &amp; HVSC Plus downconductor</li> <li>Lug Connection to HVSC Plus completed with upper termination</li> </ul> 	<ul style="list-style-type: none"> <li>Threaded GI adaptor</li> <li>Female thread 2 inch BSP for connection to GI pipe</li> </ul> 

Stormaster ESE Tester

	<ul style="list-style-type: none"> <li>Spark-over tester designed for testing the Stormaster ESE range of terminals</li> <li>Portable tester</li> <li>Visual identification of terminal operation</li> <li>Rechargeable batteries</li> </ul>
<p><b>Ordering Code</b></p>	<p><b>STORMASTER-ESE-TESTER</b></p>
<p>Description:</p>	<p>LPI® Stormaster terminal tester</p>
<p>Construction:</p>	<p>Aluminium enclosure</p>
<p>Charger operating voltage:</p>	<p>100 – 240 V</p>
<p>Batteries:</p>	<p>4 x 1.2 V rechargeable NiCad batteries</p>
<p>Dimension:</p>	<p>295 mm x 70 mm x 70 mm</p>
<p>Weight:</p>	<p>2.5 kg</p>



## TECHNICAL DATA SHEET

### Section B - LPI® Upper Termination Kit

LPI® Upper termination kit is designed for use with the LPI HVSC Plus downconductor. The upper termination kit provides all accessories for the high voltage termination of the HVSC Plus downconductor to the Stormaster ESE terminal.



Ordering Code	UTERMKIT-MK3
Description:	Upper Termination Kit Mark 3
Maximum voltage:	>500 kV 1.2/50 µs impulse
Operating temperatures:	- 20°C to + 85°C
Pack dimensions:	70 mm x 70 mm x 1250 mm
Weight:	1 kg
Contents:	Instruction, Semi-conducting tape, crimp lug, heat shrink tube, insulated friction cutting tool, insulation tape

### Section C - LPI® FRP Support Mast

LPI® Fibreglass Reinforced Plastic (FRP) mast is an insulated and water resistant mounting pole which is designed to provide the necessary electrical isolation and mounting strength at the position where the high voltage upper termination between the HVSC Plus downconductor and LPI Stormaster terminal is completed.



Description	Fibreglass Reinforced Pole (FRP)
Colour:	Black
Material :	Fibreglass
Construction type:	Pre-impregnated reinforced epoxy resin laminate (flame retardant)
Resin tensile strength:	70 MPa
Resin tensile modulus:	2.9 GPa
Resin tensile strain:	2.7%
Resin poisson ratio:	0.35

Ordering Code	Weight	Dimensions
FRP-2M	2.7 kg	Length 2000 mm, Outer diameter 68 mm, Inner diameter 60 mm
FRP-3M	4.3 kg	Length 3000 mm, Outer diameter 68 mm, Inner diameter 60 mm
FRP-4M	5.3 kg	Length 4000 mm, Outer diameter 68 mm, Inner diameter 60 mm

**TECHNICAL DATA SHEET**

**Section D - LPI<sup>®</sup> Inline Coupling**

LPI<sup>®</sup> Inline coupling is a purpose-designed coupling which enables clamping of the FRP mast to the aluminium lower mast. The inline coupling provides 3 guy anchoring points and provides an exit point for the HVSC Plus.

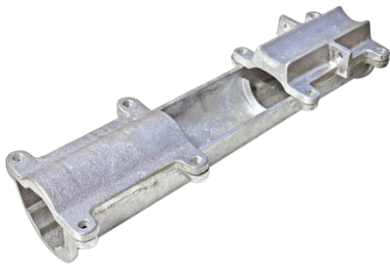

Ordering code	ILCOUPLING
Description:	Inline coupling
Material:	Cast aluminium
Dimension:	550 mm x 150 mm x 120 mm
Weight:	2.7 kg
Anchoring points:	3
Max. clamping torque:	55 kg/cm

**Section E - LPI<sup>®</sup> Guy Kit**

LPI<sup>®</sup> non-conductive and stainless steel guy kits are provided in variable lengths to suit specific mast and terminal heights. The purpose designed guying kits are designed for anchoring from a guy ring or an inline coupling.



Ordering Code	GUYKIT-4M	GUYKIT-7M
Description:	Stainless steel fittings and non conductive synthetic guy wire kits	
Material:	DYNEEMA <sup>®</sup> is an UHMWPE* fibre, non conductive, UV stabilised, moisture resistant, chemical inert	
Application:	Designed to provide additional stabilizing/securing of mast arrangement where deemed necessary	
Diameter:	4 mm	
Tensile yield strength:	560 kg	
Weight:	0.46 kg	0.53 kg

\*UHMWPE – Ultra-High Molecular Weight Polythene



Ordering Code	GUYKIT-4M-SS	GUYKIT-7M-SS
Description:	Stainless steel guy wire kits	
Material:	Stainless steel, grade 316	
Application:	Designed to provide additional stabilizing/securing of mast arrangement from the inline coupling only	
Diameter:	3.2 mm	
Tensile yield strength:	450 kg	
Weight:	0.8 kg	1.2 kg

Stainless steel guy kits are not to be used at top section of mast or with guy ring and should be anchored from the inline coupling.

## TECHNICAL DATA SHEET

### Section F - LPI® Guy Ring

LPI® guy ring provides 3 guy points for mounting between the top section of the FRP mast and the Stormaster ESE terminal.



Ordering Code	Guy Ring
Material:	Cast aluminium
Dimension:	110 mm x 110 mm x 10 mm
Weight:	0.12 kg
Guy hole diameter:	10 mm

### Section G - LPI® Lower Mast Assembly

LPI® uses an aluminium mast as the lower mast assembly due to its high strength and light weight characteristics.



Description	Aluminium Mast
Colour:	Silver
Material:	Aluminium
Inside diameter:	61.9 mm
Outside diameter:	69.9 mm

Length	3 Metres	4 Metres	5 Metres	6 Metres
Weight:	7 kg, 8 kg (with base)	9 kg, 10 kg (with base)	11.7 kg, 12.7 kg (with base)	14.4 kg, 15.4 kg (with base)
No base:	ALUM-3M	ALUM-4M	ALUM-5M	ALUM-6M
With base:	ALUMB-3M	ALUMB-4M	ALUMB-5M	ALUMB-6M
With GI male adaptor:	ALUM3M-MGI	ALUMB4M-MGI	ALUMB5M-MGI	ALUMB6M-MGI

LPI® Stormaster GI terminals suitable for use with locally supplied 2" male threaded GI pipe.

## TECHNICAL DATA SHEET

### Section H - LPI® Cantilevering Saddles

Purpose designed stainless steel saddles for cantilevering the aluminium mast of 69.9 mm outer diameter to flat vertical surface.



Ordering Code	CANTSAD
Description:	70 mm saddles for mounting of aluminium mast (3 per set)
Material:	Stainless steel
Weight:	180 g per saddle, 540 g per set
Dimension:	130 mm (L) x 70 mm (W) x 1.2 mm (D)
Hole fixing diameter:	8 mm

### Section I - LPI® U-Bolt

LPI® U-Bolt set is specifically designed to allow for the secure clamping of aluminium or FRP mast to tower section or handle rail.



Ordering Code	U-Bolt
Description:	U-Bolt, 2 per set
Material:	U-Bolt: stainless steel, Plate: aluminium
Weight:	0.75 kg per U-Bolt, 1.5 kg per set
Dimension:	80 mm diameter, 170 mm length

### Section J - LPI® Mounting Bracket

LPI® Offset brackets are designed for the offset cantilevering of aluminium support masts.



Ordering Code	Mounting Bracket
Description:	Offset bracket
Colour:	Silver
Material:	Stainless steel, 316
Nominal clamping OD:	70 mm
Weight	1 kg

### Section K - LPI® Cable Sock

LPI® Cable sock is designed for the mounting support of the HVSC Plus downconductor when installing a free standing mast arrangement.

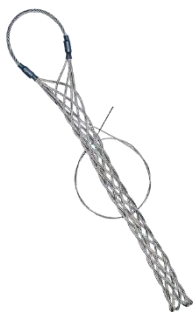

Ordering Code	Cable Sock
Description:	Cable sock for HVSC Plus support
Material:	Two-ply galvanised steel wire strand
To grip cable diameter:	28-40 mm
Grip length:	600 mm
Max. pull approx, (kn)	24

# TECHNICAL DATA SHEET

## Section L – Downconductors

### LPI® High Voltage Shielded Cable



**Withstand Voltage of  $\geq 500kV!$**

LPI’s “High Voltage Shielded Cable” (HVSC Plus) is a purpose-designed, high-integrity, low-impedance cable that is used to safely convey lightning currents to earth with minimal risk of side flashing or structure electrification. The design of the HVSC Plus incorporates carefully selected dielectric components to ensure optimum performance under the impulse or “transient” voltages and currents imposed by lightning discharges.

LPI’s new HVSC Plus provides improved features as a dedicated insulated lightning downconductor:

- Double the voltage withstand performance of past versions;
- 35% reduction in the mass per unit length of the cable;
- Improved manufacturing consistency via a continuous “triple extrusion” process;
- Reduced voltage stress via thin, semi-conductive screen layers; and
- Improved material parameters and performance.

The design of the cable is based on the optimisation of all of the key parameters associated with dealing with lightning discharges and the consequent voltage and current transients, including impedance, inductance, capacitance, insulation thickness (withstand voltage) and all of the relevant lightning statistics, plus practical aspects such as size, flexibility and mass.

**Figure 1:** Construction of the HVSC Plus lightning downconductor cable.

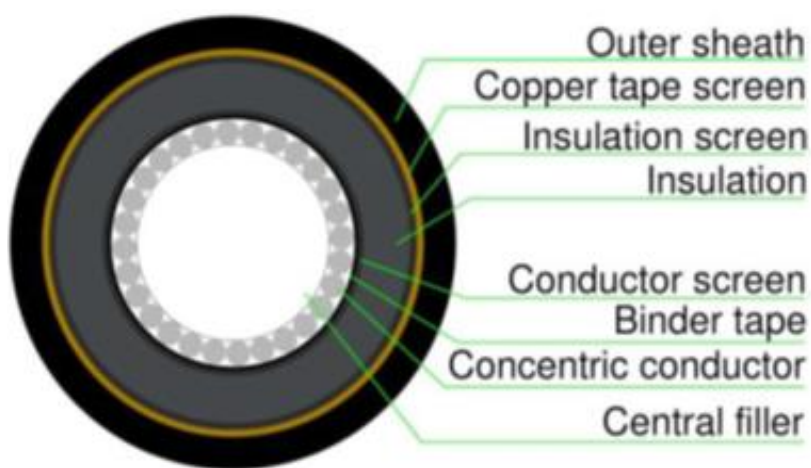

**HVSC Plus has been tested by a certified, independent high voltage laboratory located at Monash University, Australia.**

This Test Report is available on request to [info@lpi.com.au](mailto:info@lpi.com.au) or on our website [www.lpi.com.au](http://www.lpi.com.au)

<b>Product Ordering Code:</b>	<b>HVSCPLUS-PM or HVSCPLUS-500</b>
-------------------------------	------------------------------------



## TECHNICAL DATA SHEET

## Physical Specifications of HVSC Plus:

<b>Mass per unit length</b>	1.34 kg/m
<b>Construction</b>	Triple extruded
<b>Concentric conductor material</b>	Aluminium
<b>Concentric conductor XSA</b>	≥ 50 mm <sup>2</sup>
<b>Insulation</b>	5 mm (nominal) of XLPE
<b>Metallic screen</b>	Copper tape
<b>Outer sheath</b>	3 mm (nominal) of PVC, UV Stabalised
<b>Cable diameter</b>	36 mm
<b>Min. bending radius <i>before</i> installation</b>	430 mm
<b>Min. bending radius <i>after</i> installation</b>	358 mm

## Electrical Specifications of HVSC Plus:

<b>Conductor DC resistance @ 20°C</b>	0.641 Ω/km
<b>Conductor DC resistance @ 90°C</b>	0.821 Ω/km
<b>Insulation resistance @ 20°C</b>	5000 MΩ
<b>Inductance</b>	93 nH/m
<b>Capacitance</b>	285 pF/m
<b>Impedance</b>	18 Ω
<b>Withstand voltage (1.2/50 μs impulse)</b>	≥ 500 kV

## TECHNICAL DATA SHEET

### LPI® Copper Tape

LPI® 25 mm x 3 mm soft drawn copper tape is manufactured using the latest, European developed extrusion technologies. LPI® FL6T253C is a high-quality tape which provides our customers with a guaranteed copper purity of 99.95%. FL6T253C is ideal for use as a conventional means of conveying lightning energy to ground.



Ordering Code	FL6T253C
Description:	Copper tape 25 x 3 mm (soft drawn)
Material:	99.95% Copper
Dimension:	25.00 mm (Width) x 3.00 mm (Thickness)
Weight:	0.67 kg per metre
Electrical conductivity:	Minimum 100% I.A.C.S
Standard:	BS1432
Tensile strength:	210 - 250 N/mm <sup>2</sup>
Package:	Supplied in pancake coil form (50 m per coil)

NFC 17-102 (2011)/EN 50164-2 has a requirement for copper and aluminium downconductors to have a cross-sectional area of 50 mm.

### LPI® Aluminium Tape



Ordering Code	FL6T253A
Description:	Aluminium rape 25 x 3 mm (soft drawn)
Material:	Aluminium
Dimension:	25.00 mm (Width) x 3.00 mm (Thickness)
Weight:	0.2 kg per metre
Electrical conductivity:	>60% I.A.C.S
Package:	Supplied in pancake coil form (50 m per coil)

NFC 17-102 (2011)/EN 50164-2 has a requirement for copper and aluminium downconductors to have a cross-sectional area of 50 mm.

### LPI® Stranded Copper Cable

LPI® soft drawn stranded copper cable is ideal for use as a conventional means of conveying lightning energy to ground. The cable is manufactured in compliance to BS6360.



Ordering Code	SCC70
Description:	Stranded copper cable 70 mm <sup>2</sup>
Material:	Copper
Cross section/diameter:	70 mm <sup>2</sup> / 2.14 mm Dia
Weight:	0.62 kg per metre
Stranding No.	19

## TECHNICAL DATA SHEET

### Section M - LPI® Cable Ties

LPI® Cable ties are designed for securing the HVSC Plus downconductor to structures and mast assembly.

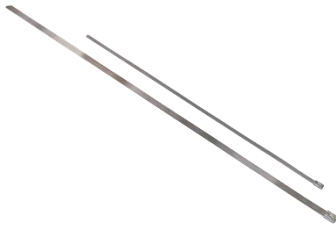

Ordering Code	SS-CABTIE-STD	SS-CABTIES-L
Description:	Cable ties	
Material:	Stainless steel	
Length:	360 mm	520 mm
Width:	7.9 mm	7.9 mm
Weight	10 g	10 g

### Section N - LPI® Saddles and Fixings

#### LPI® Saddles

LPI® SAD FIX are specially designed for securing of HVSC Plus downconductor to structures.



Ordering Code	SAD FIX
Description:	Saddles and fixings
Material:	Stainless steel, grade 304
Dimension:	90 mm Length, 1.2 mm thickness
Fixing hole diameter:	7 mm
Weight:	40 g



Ordering Code	SAD FIX-70
Description:	Saddles to suit 70 mm <sup>2</sup> cable
Material:	Stainless steel, grade 316
Dimension:	44 mm Length, 1 mm thickness
Fixing hole diameter:	7 mm
Weight:	5 g

#### LPI® D.C Tape Clip

LPI® D.C Tape Clips are designed for the securing of Copper or Aluminium Tape to structures.



Ordering Code	FL3DCTC253C	FL3DCTC253A
Description:	D.C tape clip to suit 25 mm x 3 mm tape	
Material:	High strength copper alloy	High strength aluminium alloy
Conductor size:	25 x 3 mm	
Weight:	43 g	17 g

## TECHNICAL DATA SHEET

### LPI® Plastic Tape Clip

LPI® Plastic tape clips are designed for securing of copper and aluminium tape to structures.



Ordering Code	FL3PTCB253	FL3PTCG253
Description:	Plastic tape clip to suit 25 mm x 3 mm tape	
Material:	Plastic	
Conductor size:	25 x 3 mm	
Weight:	10 g	
Colour	Brown	Grey

### LPI® Square Tape Clamp

LPI® Square tape clamps are designed to allow for the 2 and 4 way routing of copper and aluminium downconductors.

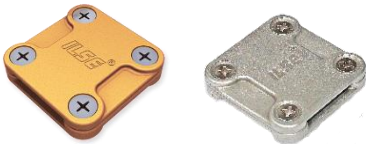

Ordering Code	FL4STC253C	FL4STC253A
Description:	Square tape clamp to suit 25 mm x 3 mm tape	
Material:	High strength copper alloy	High strength aluminium alloy
Conductor size:	25 x 3 mm	
Weight:	168 g	78 g

### LPI® Oblong Test Clamp

LPI® Oblong test clamp are designed to allow for the disconnection of copper and aluminium downconductors for testing purposes.



Ordering Code	FL4OTC253C	FL4OTC253A
Description:	Oblong test clamp to suit 25 mm x 3 mm tape	
Material:	High strength copper alloy	High strength aluminium alloy
Conductor size:	25 x 3 mm	
Weight:	126 g	118 g

### Section O - LPI® Beam Clamp and Cable Support

LPI® Beam clamp and cable support are specifically designed for the securing of the HVSC Plus downconductor to tower legs.



Ordering Code	BEAM CLAMP / CABLE SUPPORT - HVSC
Description:	Beam clamp and cable support
Material:	Stainless steel, polymer
Dimension:	60 mm x 60 mm x 50 mm
Fixing hole diameter:	38 mm
Weight:	180 g

**TECHNICAL DATA SHEET**

**Section P - LPI<sup>®</sup> Lightning Strike Recorder**

LPI<sup>®</sup> Lightning Strike Recorder (LSR1) is a lightning strike counter. The LSR1 is simply mounted at any location along the downconductor route. Its purpose is to record the number of strikes captured and conveyed by the downconductor.



Ordering Code	LSR1
Description:	Lightning strike recorder
Current sensitivity:	1500 A 8/20 µs impulse
Operating range:	Min. 1500 A and Max. 220 kA 8/20 µs
Display:	Mechanical 7 digits display (not re-settable).
Dimension:	100 mm (B) x 100 mm (H) x 55 mm (D)
Weight:	0.57 kg
Mounting:	Releasable UV resistant plastic cable ties suitable for up to ø40 mm cable or 50 x 5 mm flat tape
Construction:	Polycarbonate enclosure
Colour:	Light grey & blue
Environment:	IP 67 (IEC 529)
Operating temperature:	-15°C to 65°C

**LPI<sup>®</sup> Lightning Strike Recorder Tester**

LPI<sup>®</sup> Lightning strike recorder tester is a high-current injection device designed to trigger a reading on an LPI Lightning Strike Recorder (LSR1).



Ordering Code	LSR1-TESTER MKII
Description:	Lightning strike recorder tester
Impulse output:	2 kA peak simulated lightning impulse
Open circuit output:	55 Volts
Time between impulses:	20 seconds
Display:	Red "Testing" LED indicator
Dimensions:	190 mm (L) x 100 mm (W) x 35 mm (H)
Mounting:	Portable unit, no mounting required
Construction:	Polycarbonate Enclosure, IP 30 rating
Colour:	Light grey
Weight:	0.58 kg
Working temperature:	-15°C to 65°C
Batteries:	8 x AA 2000 mAh NiMH rechargeable Recharge time up to 16 hours

**TECHNICAL DATA SHEET**

**Section Q - LPI<sup>®</sup> Lower Termination Kit**

LPI<sup>®</sup> Lower termination kit provides accessories and tools for the termination of the HVSC Plus lower end to the dedicated lightning earth.



Ordering Code	<b>LTERMKIT-MK3</b>
Description:	Lower termination kit
Pack Dimensions:	270 mm (B) x 100 mm (H) x 40 mm (D)
Weight:	515 g
Contents:	1 x 95 mm crimp lug 1 x waterproofing tape 1 x earth rod clamp 2 x warning labels 1 x insulation friction cutting tool

Suitable for use with conventional downconductors as required.

**Section R - LPI<sup>®</sup> Denso Tape**

Denso Tape is used to waterproof earthing installations and prevent corrosion.



Ordering Code	<b>DENSO-25mm</b>	<b>DENSO-50mm</b>
Description:	Waterproofing tape	
Material:	Synthetic fabric, impregnated and coated with a neutral petrolatum compound	
Pack:	25 mm x 10m	50 mm x 10m
Weight:	400 g	800 g

# TECHNICAL DATA SHEET

## Section S - LPI® Earthing System LPI® Copper Bonded Earth Rods

LPI® Copper-bonded earth rods are made from high-tensile low-carbon steel and each rod is manufactured by molecularly bonding 99.9% pure electrolytic copper to the low-carbon steel core in accordance with national and international standards such as BS6651, BS7430 and UL467. Threads are rolled onto the rod, ensuring an even copper covering which eliminates the risk of chipping whilst driving.



Other sized rods available.

Ordering Code	CBER1214
Description:	Threaded copper bonded earth rod
Material:	Carbon steel bonded with copper
Length:	1.2 m
Rod diameter (actual):	14.3 mm
Threaded diameter:	5/8" UNC
Weight:	1.54 kg

## LPI® Stainless Steel Earth Rods

LPI® Solid stainless steel earth rods are manufactured using 316 grade stainless steel and are highly resistant to corrosion. Stainless steel rods are best used for earthing installations where the problem of galvanic corrosion may take place between dissimilar metals buried in close proximity to each other and where highly corrosive soil conditions exist. All solid stainless steel earth rods manufactured by LPI are supplied with external threads.



Other sized rods available.

Ordering Code	SSER1215
Description:	Threaded stainless steel earth rod
Material:	316 grade stainless steel
Length:	1.2 m
Rod Diameter (Actual):	15.8 mm
Threaded Diameter:	5/8" UNC
Weight:	1.90 kg

## LPI® Coupling for Copper Bonded and Stainless Steel Threaded Earth Rods

Whether connecting rod-to-rod or driving stud-to-rod the high strength copper alloy coupling is counter-bored to protect the earth threads from damage and subsequent corrosion.



Ordering Code	LEH-58R	LEH-58R-SS
Description:	Coupling for threaded Copper bonded earth rod 5/8"	Coupling for threaded Stainless steel earth rod 5/8"
Material:	High strength copper alloy	316 stainless steel
Thread type:	5/8" UNC	
Weight:	106 g	113 g

## TECHNICAL DATA SHEET

**LPI® Copper Tape**

LPI® 25 x 3 mm soft drawn copper tape is manufactured using the latest European developed extrusion technologies. LPI® FL6T253C is a high-quality tape which provides our customers with a guaranteed copper purity of 99.95%. Flat copper tape in comparison to stranded copper cable is considered as the most efficient conductor for the transfer of lightning energy to the ground mass. Flat tape provides greater surface contact with the surrounding soil which assists greatly in the dissipation of the lightning energy.



Ordering Code	FL6T253C
Description:	Copper tape 25 x 3 mm (soft drawn)
Material:	99.95% Copper
Dimension:	25.00 mm (Width) x 3.00 mm (Thickness)
Weight:	0.67 kg per metre
Electrical conductivity:	Minimum 100% I.A.C.S
Standard:	BS1432
Tensile strength:	210 - 250 N/mm <sup>2</sup>
Package:	Supplied in pancake coil form (50 m per coil)

**LPI® Rod to Tape Clamp Type A**

LPI® Rod to tape clamp provides a conductive and mechanically secure connection when installing a lightning protection earth encompassing flat copper tape and copper bonded earth rods.



Ordering Code	RTC253
Description:	Rod to tape clamp to suit 14-17 mm Dia rod & 25 x 3 mm tape
Material:	High strength copper alloy
Rod Diameter:	14-17 mm
Conductor size:	25 x 3 mm
Weight:	120 g



# TECHNICAL DATA SHEET

## Section T - LPI® Inspection Pits

LPI® Inspection pits provide a secure and user-friendly access point for maintenance purposes and the periodical measurement of electrical resistance of a buried earthing system. In order to complete routine measurements of electrical resistance, simply remove the lid from the installed earth pit and connect a lead from the resistance meter to the earthing conductor.



Ordering Code	EPIT-P
Description:	Polymer earth pit
Material:	Polymer
Dimension:	250 mm (top) x 180 mm (base) x 210 mm (deep)
Weight:	1.9 kg
Strength:	Withstand up to 5 tonnes

## Section U - LPI® Earthing Compounds LPI® GRIP

LPI® Ground Resistance Improvement Powder (GRIP) is a premium product designed to reduce soil resistivity in the poorest soil conditions. When GRIP is mixed with water and poured onto the earthing system and surrounding soil, the powder and water react to form a gelatinous mass which will not reduce, contract or separate from the earth electrodes its surrounds.



Ordering Code	GRIP-10	GRIP-40
Description:	Ground resistance improvement powder	
Application:	To assist in achieving an earth resistance of less than 10 Ohms	
Weight:	Part A = 5 kg Part B = 5 kg	Part A = 20 kg Part B = 20 kg

## LPI® RESLO

LPI® RESLO-10 is a low-resistance, non-corrosive, bentonite-based earth enhancing compound which is supplied in easy-to-handle 10 kg bags.



Ordering Code	RESLO-10
Description:	Resistance lowering compound – 10 kg Bag
Application:	To assist in achieving an earth resistance of less than 10 Ohms
Weight:	10 kg

# TECHNICAL DATA SHEET

## Section V - LPI® Chemical Ground Rod

LPI® Chemical ground rod provides a low-impedance earth to effectively dissipate lightning and electrical fault currents. The chemical ground rod is ideal in situations where space is restricted and normal lightning earths such as radial and grid-type systems cannot be installed.



Ordering Code	CHEMROD-2M	CHEMROD-3M
Length:	2 m	3 m
Diameter:	63.5 mm	
Copper composition:	99.9% minimum	
Standard:	Australian Standard AS1432	
Melting point:	1083°C	
Specific heat capacity:	0.385 kJ (kg.K)	
Electrical conductivity (Annealed):	75-90% I.A.C.S.	
Wall thickness:	1.6 mm	
Copper:	Hard-drawn	
Cap:	Removable type with air breather holes	
Drainage holes:	4.5 mm diameter, provided every 40 cm for the length of the rod	
Mineral salts:	Pre-filled from factory with non-hazardous natural electrolytic salts	
Pigtail:	70 mm stranded copper cable, pre-welded from factory to allow for connection to earthing system	
Weight:	12 kg (CHEMROD) 40 kg (RESLO)	21 kg (CHEMROD) 60 kg (RESLO)

TECHNICAL DATA SHEET

**Recommended Earthing Installation**

This type of radial earth is recommended for installation as a lightning protection earth.

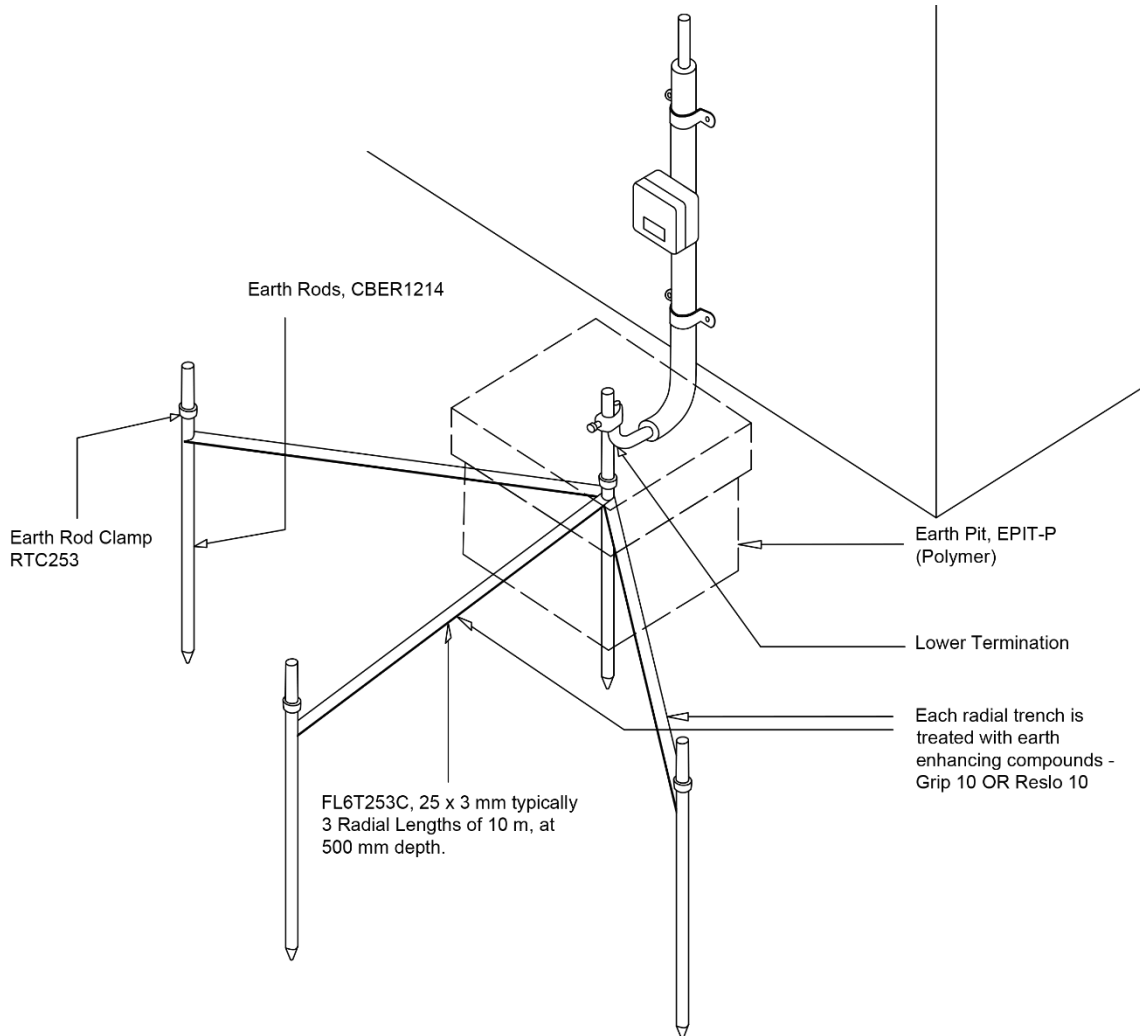

**ISO 9001 Certificate**

Lightning Protection International Pty Ltd operates a certified management system that complies with the requirements of AS/NZS ISO9001:2008. Certificate can be provided on request.



Head Office | 49 Patriarch Drive, Huntingfield Tasmania, Australia 7055  
 Postal | PO Box 379 Kingston, Tasmania, Australia 7051  
 Web | www.lpi.com.au

Phone | + 61 3 6281 2475  
 Facsimile | + 61 3 6229 1900  
 Email | info@lpi.com.au